

(No Model.)

W. LODGE.
LATHE CARRIAGE.

No. 396,700.

Patented Jan. 22, 1889.

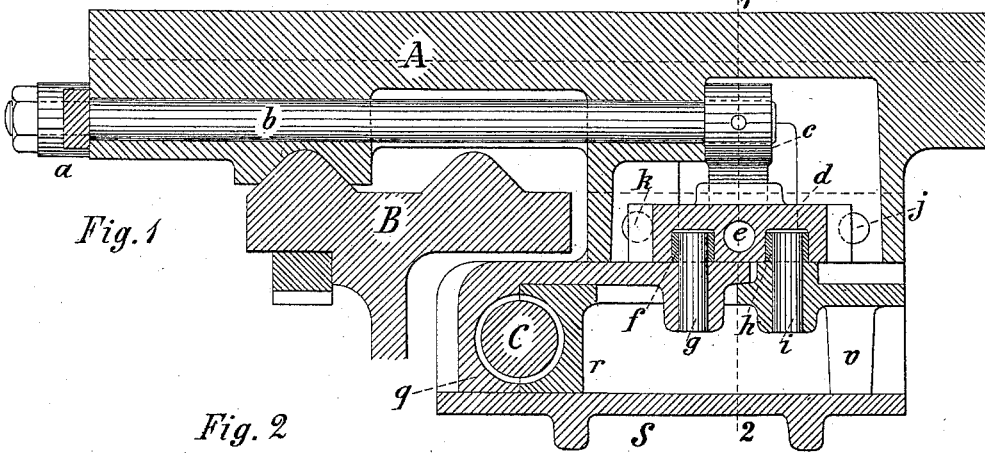

Fig. 1

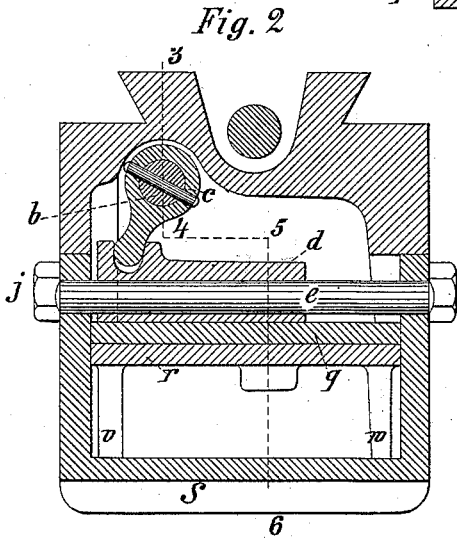

Fig. 2

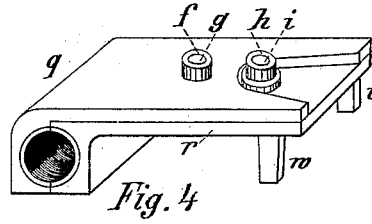

Fig. 4

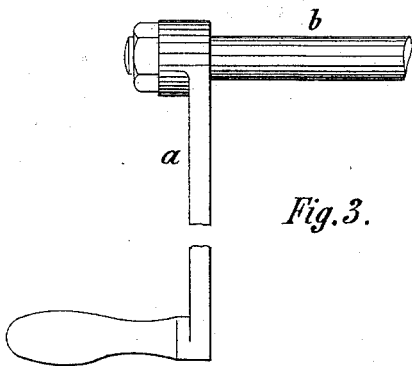
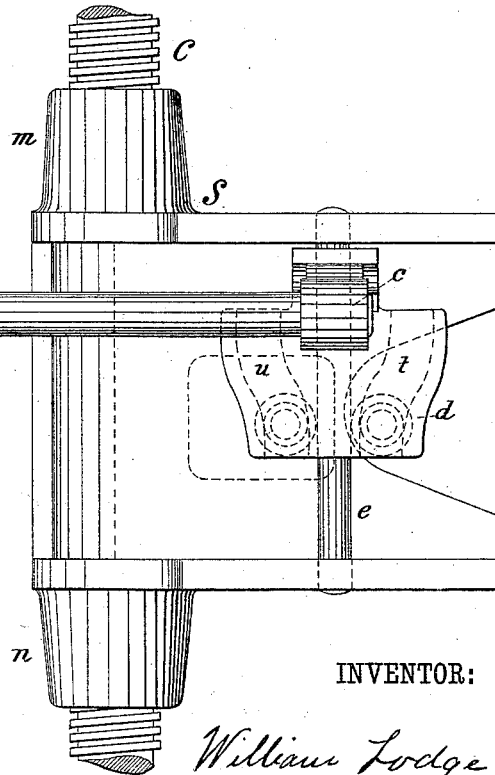

Fig. 3.



WITNESSES:

H. Presser,
J. M. de Rose

INVENTOR:

William Lodge.

UNITED STATES PATENT OFFICE.

WILLIAM LODGE, OF CINCINNATI, OHIO.

LATHE-CARRIAGE.

SPECIFICATION forming part of Letters Patent No. 396,700, dated January 22, 1889.

Application filed May 18, 1888. Serial No. 274,340. (No model.)

To all whom it may concern:

Be it known that I, WILLIAM LODGE, a citizen of the United States, residing at Cincinnati, in the county of Hamilton and State of Ohio, have invented a new and useful Improvement in Lathes, of which the following is a specification.

My invention relates to the screw-cutting mechanism in lathes; and it consists of a new and useful device for connecting and disconnecting the carriage or saddle with the lead-screw.

The objects of my invention are, first, to lay the lead-screw in the inside of the lathe-bed close to the center of gravity of the combined tool carrying and feeding mechanism and as near as possible to the resistance caused by the cutting-tool, and thus avoiding excessive strain on the carriage and lead-screw; second, to journal the lead-screw on both sides of the half-nuts, so as to prevent the same from bending and sagging; third, to so combine the box holding the half-nuts with the carriage as to form an almost solid body, and, fourth, to have a device both substantial and operative from the front of the lathe. I attain these objects by the mechanism illustrated in the accompanying drawings, in which—

Figure 1 is a longitudinal section through a well-known carriage and front ways of a lathe on the line 3 4 5 6, Fig. 2, with my improvement attached to it. Fig. 2 shows a section through a cross-bridge of a carriage in connection with my improved device on the section-line 1 2, Fig. 1. Fig. 3 is a top view of my invention detached from the carriage, and Fig. 4 shows the half-nuts in a perspective view.

Similar letters refer to similar parts throughout the several views.

In Fig. 1, A represents the carriage, and B the front ways, of a lathe. *b* is a rod journaled in the carriage, having on its front end an actuating-crank, *a*, and on the other end a lever, *c*, secured to it. Lever *c* engages with a cam, *d*, sliding on bar *e*, fixed on both ends in box S. Box S is of a rectangular shape, fits sidewise tightly over suitable projections cast on the lower part of the carriage cross-bridge,

is held in place by four symmetrically-placed screws, of which two, *j* and *k*, can be seen in Fig. 1, and so located as to move in the inside of the lathe-bed. Its front end extends under the inside of the front ways, B, and forms on both sides tubular extensions *m* and *n*, through which passes the lead-screw C, and journals the same. By this construction said lead-screw is prevented from bending and sagging, and at the same time is shielded from dirt and shavings. The inside of box S receives the two half-nuts *q* and *r* and guides them on their sides and bottom.

The half-nuts *q* and *r* slide with their wings on top of each other, and are so constructed that the upper wing forms the outer half and the lower one the inner half of the nut. The parts forming the nut in front and the legs *w* and *v*, cast on half-nut *r*, serve as supports. By means of suitable lugs cast on the wings, studs *g* and *i*, mounted with rollers *f* and *h*, are secured to them. The lug on the lower wing passes through an opening in the top one to bring both rollers into the same plane and allow the necessary movement.

The rollers *f* and *g* engage, respectively, with the grooves *u* and *t* in cam *d*, and the latter serves on its bottom as a guide for the half-nuts, so as to make the whole mechanism self-contained.

To open the half-nuts, crank *a* is given about a quarter of a turn to the left, which moves cam *d* to the right, and as its grooves *u* and *t* diverge also studs *g* and *i*, with half-nuts *q* and *r*, follow this direction, and thus disconnects the carriage from the lead-screw, and vice versa.

Having thus described the mode of operation, I claim as new, and desire to secure by Letters Patent, the following:

1. The combination, with a lathe-bed having a lead-screw mounted inside of the same under the front shear, of a carriage having secured to the lower part of its cross-bridge the rectangular box S, provided on each side with the extension tubular journals for the lead-screw, substantially as set forth.

2. In a lathe, the combination, with the carriage thereof, having the box S, of the sliding

can *d* and the half-nuts *q* and *r*, having the wing of one superposed upon the other and provided with the roller-capped studs engaging the grooves of said cam, substantially as described.

5 3. The combination, in a lathe, of the carriage and its box *S*, the rod *b*, journaled in the carriage and having at one end an actuating-

crank and at the other a lever, *c*, the sliding cam actuated by said lever, and the half-nuts 10 with their studs in engagement with said cam, substantially as described.

WILLIAM LODGE.

Witnesses:

E. D. GOODWIN,

BURT. DOAN.